



# AMD Direct

---

**WARMING DRAWER  
USER MANUAL**

---



## AMD DIRECT WARMING DRAWER

INSTALLATION INSTRUCTIONS & OWNERS MANUAL

NAME: ELECTRIC WARMING DRAWER RATED 120V, 60 HZ, 8A

PART #: SSWD-36

### THANK YOU

Thank you for your purchase. We'd like to welcome you to the AMD Direct family of luxury outdoor kitchen products and look forward to being a part of your home for years to come. As a family business with over 20 years of industry experience, we aim to deliver exceptional quality and personal service. Welcome to the AMD Direct family and we hope you love your new warming drawer!



For warranty information and to register your product visit, [amddirect.com/register](http://amddirect.com/register)

To view on your phone, scan the QR code on your camera app. (For Android devices, use Google Lens)



### INSTALLER

Please leave this manual for the owner

\_\_\_\_\_

Serial Number: \_\_\_\_\_

Model: \_\_\_\_\_

Date of Purchase: \_\_\_\_\_

Place of Purchase: \_\_\_\_\_

## SAFETY INSTRUCTIONS

Read the following instructions carefully and be sure your warming drawer is properly installed, assembled and cared for. Failure to follow these instructions may result in serious bodily injury and/or property damage, if you have questions concerning assembly or operation, consult your dealer or appliance service representative.

### NOTE TO INSTALLER

Leave these instructions with the consumer after installation.

### NOTE TO CONSUMER

Retain these instructions for future reference. This outdoor cooking electric appliance is not intended to be installed in or on recreational vehicles and/or boats.



### ELECTRICAL REQUIREMENTS

#### ⚠ WARNING ⚠

##### ELECTRIC SHOCK HAZARD

- Plug into a grounded 3-prong outlet
- Do not remove ground prong
- Do not use an adapter
- Do not use an extension cord
- Failure to follow these instructions can result in death, fire, or electric shock

- Electrical: 120 Volt, 60 Hz, AC Only 15- or 20- amp.
- Use copper wire only.
- A time-delay or circuit breaker and separate circuit is recommended.
- **Important:** Observe all governing codes and ordinances. It is the customer's responsibility:
  - To contact a qualified electrical installer.
  - To assure that the electrical installation is adequate and in conformance with National Electrical Code.
- ANSUNFPA 70 — latest edition\* or
  - CAN/CSA-C22.2 No. 0-M91
  - CAN/CSA-C22.2 No. 0.4-04
  - CAN/CSA-C22.2 No. 64-M91
  - UL 1026, 5Th Edition and all local codes and ordinances.

- You must have:
  - 120-volt, 60Hz, AC-only, 15- or 'H- amp., fused electrical supply
  - Outlet located in the cabinet as close as possible to the warming oven.
- We recommend:
  - A time-delay fuse or circuit breaker
  - a separate circuit serving this appliance only
- If codes permit and a separate ground wire is used it is recommended that a qualified electrician determine that the ground path is adequate.
- Copies of the standards listed may be obtained from:
  - National Fire Protection Association  
1 Batterymarch Park Quincy,  
Massachusetts 02169-7471
  - Canadian Electrical Association  
175 Rexdale Boulevard

## SAFETY INSTRUCTIONS

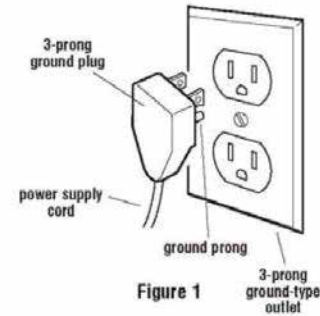

For your personal safety, this appliance must be grounded. This appliance is equipped with a power supply cord having 3-prong ground plug. To minimize possible shock hazard, the cord must be plugged into a mating 3-prong ground-type outlet grounded in accordance with local codes and ordinances. See Figure 1. If a grounded outlet is not available, it is the personal responsibility and obligation of the customer to have a properly grounded 3-prong outlet, installed by a qualified electrician.

Warning — Improper connection of the equipment-grounding conductor can result in a risk of electric shock. Check with a qualified electrician or serviceman if you are in doubt as to whether the appliance is properly grounded. Do not modify the plug provided with the appliance - If it will not fit the outlet, have a proper outlet installed by a qualified electrician.

#### ⚠ WARNING ⚠

- Proper Installation — Be sure the warming drawer is properly installed and grounded by a qualified technician.
- Do Not Leave Children Alone — Children should not be left alone or unattended in area where warming drawer is in use. They should never be allowed to lie, sit or stand on any part of the warming drawer.
- Wear Proper Apparel — Loose-fitting or hanging garments should never be worn while using the warming drawer.
- User Servicing — Do not repair or replace any part of the warming drawer unless specifically recommended in the manual. All other servicing should be referred to a qualified technician.
- Storage in Warming Drawer— Flammable materials should not be stored in a warming drawer.
- Do Not Use Water on Grease Fires — Smother fire or flame or use dry chemical or foam-type extinguisher.
- Use Care When Opening Drawer — Let hot air or steam escape before removing or replacing food.
- Use Only Dry Potholders — Moist or damp potholders on hot surfaces may result in burns from steam. Do not let potholder touch hot heating elements. Do not use a towel or other bulky cloth.
- Do Not Heat Unopened Food Containers — Build-up of pressure may cause container to burst and result in injury.
- DO NOT TOUCH HEATING ELEMENTS OR INTERIOR SURFACES OF WARMING DRAWER — Heating elements may be hot even though they are dark in color. Interior surfaces of a warming drawer become hot enough to cause burns. During and after use, do not touch, or let clothing or other flammable materials contact heating elements or interior surfaces of warming drawer until they have had sufficient time to cool. Other surfaces of the warming drawer may become hot enough to cause burns — among these surfaces the warming drawer vent openings and surfaces near these openings and warming drawer doors.



---

## WARMING DRAWER USER MANUAL

---

### TABLE OF CONTENTS

INSTALLATION	1
OPERATING INSTRUCTIONS	2
CLEANING & MAINTENANCE	3
TROUBLESHOOTING GUIDE	3
PARTS LIST	4
WARRANTY	5

# INSTALLATION

## ISLAND INSTALLATION

1. Provide a 10 1/8" H x 34 1/2" W x 21" D cutout to the front of the island.
2. Provide support beams using metal studs.
3. Pull the drawer out of the drawer casing to gain access to the mounting holder at the front of the casing.
4. Insert the drawer casing into the island opening.
5. Secure the drawer casing with screws at the inside front top and bottom, using the pre-punched mounting holes.
6. Re-assemble the drawer section into the drawer casing.
7. Apply weather-proof sealant along the edges of the warmer. (Not Included)
8. Plug-in the warmer to a properly grounded, weather-proof, electrical outlet.

## EXTENSION CORD

- Be sure that the warming drawer is properly grounded and installed by a qualified technician. The electrical cord has a 3 prong plug. Do not cut any of the prongs.
- Make sure that the island is free of cracks that would allow water or other liquids to get into the electrical controls.
- Keep the warming drawer away from water sprinklers.

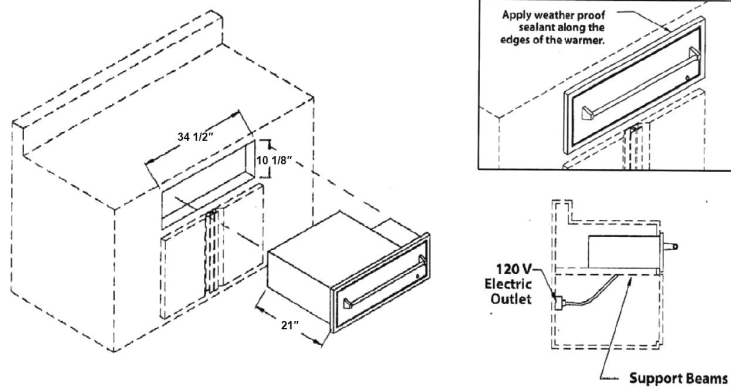

# OPERATING INSTRUCTIONS

## TEMPERATURE CONTROLS

- The temperature control dial is used to select the temperature of the warming drawer. It is located on the right hand side of the control panel and has dial settings from 50°F-230°F.
- The warming drawer should only be opened when adding or removing food. Continuous opening of the drawer allows warm air to escape and make the food colder.
- Do not use aluminum foil to line the drawer. Foil is an excellent heat insulator and will trap heat beneath it. This may affect the performance of the warming drawer, the interior finish and possibly be a safety issue.

## HEAT-ON LIGHT

- The heat-on light is located above the temperature control knob. The red light turns on when the control knob is set and cycles "on" and "off" with the heating element as temperature is maintained.

## HEATING INSTRUCTIONS

- Dry Heat
  - The main function of the warming drawer is to hold hot cooked foods at serving temperature.
  - For crispy foods, slide the moisture vent control inward to open the vents and allow the moisture to escape.
  - Set the temperature control dial, Heat-on light will appear until the desired temperature is reached.
- Moist Heat
  - The warming drawer also seals moisture within the drawer to keep the food moist.
  - Put just enough water, approximately 1/2" high, in the steam pans. (Not Included)
  - Place the steam rack inside the steam pan. (Not Included)
  - Place the food directly on the rack or use a suitable container that will fit in the steam pans. Do not use plastic containers or utensils.
  - Slide the moisture vent control outward to close the vents and seal the moisture inside the drawer.
  - Set the temperature control dial. Heat-on light will appear until the desired temperature is reached.
  - Periodically, check the water level in the steam pans and add water when necessary.
- Proofing Yeast Dough
  - Yeast dough can be proofed in a warming drawer.
  - Place the dough in a bowl and turn the temperature control at the lowest setting, to facilitate the fermentation process.
  - Place a towel over the dough to minimize surface drying.
  - Let the dough remain in the warming drawer until it has doubled in size and a slight depression remains when the surface is touched gently with a finger.

## CLEANING AND MAINTENANCE

### VISIBLE DAMAGE

1. Allow the warming drawer and its accessories to cool before cleaning.
2. Clean all items including the drawer with the mildest cleanser. Scrub dirt with sponge.
3. When cleaning the front panel, always scrub in the direction of the grain. In order to maintain the luster and highlights of polished surface, do not use abrasives when cleaning polished surfaces. Use the mildest cleaner.
4. Do not use steel wool to clean the drawer and accessories.
5. Check out the slide rails and make sure they are clean and free from debris.
6. It is highly recommended to clean the warming drawer after every use.

## TROUBLESHOOTING

Many common problems can be solved easily, saving you the time spent communicating with customer service. Try the suggestions below to see if the issue has a simple solution.

PROBLEM	POSSIBLE CAUSE
Warming Drawer will not heat up Heat-light will not come on	Check if the unit is plugged in to an electrical outlet. Check if the temperature control dial is set properly. Check if the circuit breaker is open.
If service is required:	Call your dealer. Provide the following info - Model Number - Serial Number - Date Purchased - Name of dealer where the unit was purchased from

## PARTS LIST

1. Heating Element
2. Thermostat
3. Chrome Bezel
4. Heat on Light
5. Control Knob
6. Roller Guides
7. Drawer Handle
8. Handle Bracket
9. Drawer
10. Steam Pan Guide

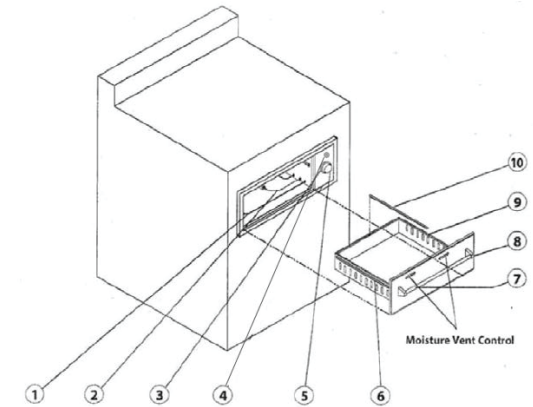

### HOW TO ORDER REPLACEMENT PARTS

Please refer to the parts list on this page. To make sure you obtain the correct replacement parts for your warming drawer, the following information is required to assure getting the correct part.

1. Model number (see data sticker on unit)
2. Reference number of replacement part needed.
3. Description of replacement part needed
4. Quantity of parts needed.

### IMPORTANT

- Use only factory authorized parts. The use of any part that is not factory authorized can be dangerous. This will also void your warranty.
- Keep this operating instruction manual for referral and for replacement parts ordering.



THIS PAGE INTENTIONALLY LEFT BLANK

THIS PAGE INTENTIONALLY LEFT BLANK



---

## GOLD STANDARD WARRANTY

---

Your investment in AMD Direct products is backed by the strongest warranty in the industry. In addition to precision engineering and outstanding performance, AMD Direct products include our GOLD STANDARD LIFETIME WARRANTY with all replacement parts 100% non-prorated. Effective with purchases as of 3/1/23.

AMD Direct Warranty is valid for original purchaser at original site of delivery with proof of purchase and photo documentation only. Registration form must be submitted online within 30 days of the purchase date to validate the warranty. Warranty is void upon transfer of ownership. Warranty does not apply to products installed in any commercial, rental, or nonresidential application that have not maintained proper upkeep. Warranty covers replacement parts only. Manufacturer is not responsible for labor or labor-related costs. Warranty does not cover discoloration, surface rust, corrosion, or oxidation, which may occur due to harsh environments, chemicals, or overheating. Warranty will not apply for damage resulting from improper installations, abuse, extreme environments, grease fires, or misuse. Proof of regular and proper maintenance is required. Coastal, humid, and/or salt environments are subject to manufacturer review. All out-of-box claims must be made within 30 days of purchase and must be made prior to installation. Any product installed damaged will be considered damaged during installation and not covered under warranty. Warranty and registration forms are available at [www.amddirect.com/register](http://www.amddirect.com/register). Please be advised - all display models are sold "as is" and the warranty covers the following items only: main burners (Gold Standard Lifetime Warranty), grates (Gold Standard Lifetime Warranty), burner covers (Gold Standard Lifetime Warranty). All warranties are subject to the review and approval of the manufacturer.

---

14520 DELTA LANE SUITE 105,  
HUNTINGTON BEACH, CA 92647

800.966.8126

AMDDIRECT.COM

### AMD DIRECT GAS APPLIANCES (GRILLS, SIDE/POWER BURNERS, GAS GRIDDLE & OVEN)

- Gold Standard Lifetime Warranty on Construction and Manufacturer Defects
- Gold Standard Lifetime Warranty on Stainless Steel Construction
- Gold Standard Lifetime Warranty on Cooking Grates, Burners, Burner Covers, Valves, Flame Tamers, and Heat Zone Separators, Temperature Gauges, & Hood Springs
- Gold Standard Lifetime Warranty on Briquette Systems
- 3 Year Warranty on all Other Parts, Components, & Electrical, Including: LED Bulbs, Wire Harness, & Switches; Power Source Wire; Transformer; Interior Halogen Light Wire & Bulb

### VENT HOODS

- 5 Year Warranty on all Stainless Steel Construction
- 3 Year Warranty on Blowers, LED Lighting, Wiring Harness and Switches

### 15" & 24" REFRIGERATION MODELS

- 3 Year Warranty on all Construction Including Compressors
- 1 Year Warranty on Transformer, LED Bulbs, LED Harness, Power Source Wire, LED Switches, Interior Halogen Light Wire/Bulbs

### 21" REFRIGERATION MODELS

- 1 Year Warranty on all Construction & Electrical Components Including Compressor, Transformer, LED Bulbs, LED Harness, Power Source Wire, LED Switches, Interior Halogen Light Wire/Bulbs

### COLD STORAGE & SINKS

- Gold Standard Lifetime Warranty on Ice Chests
- Gold Standard Lifetime Warranty on Drains & Faucets

### DRAWERS, DOORS, GRILL LINERS, & CARTS

- Gold Standard Lifetime Warranty on Construction, Workmanship and Materials for all Stainless Steel Parts, Including Doors, Drawers, Grill Liners, & Carts
- 3 Year Warranty on Electrical (Warming Drawers)

### COVERS

- Gold Standard Lifetime Warranty on Covers, Including Grills, Carts, Side/Power Burners, Gas Griddle & Oven

### COMMERCIAL APPLICATIONS

#### GAS GRILLS

- Gold Standard Lifetime Warranty on Workmanship, Construction, & Manufacturer Defects for All Commercial and/or Hospitality Applications
- Warranty is Void Upon Misuse, Including Lack of Regular Cleaning, Vandalism, or Theft
- Warranty is Valid Only if Regular Maintenance is Exercised. Due to the Nature of Commercial Applications (Multiple Users, Lack of Control of Use, etc.) Regular Maintenance is Mandatory



AMD Direct 

---

**CONTACT US**

14520 Delta Ln,  
Suite 105  
Huntington Beach, CA 92647

[AMDDirect.com](http://AMDDirect.com)

(800) 966-8126  
M–F 8:30 am – 5:00 pm (PST)

---

VER.41622